

Silo



800L ABOVE GROUND TANK

/ SAVES TIME, SPACE, AND MONEY

/ TANK DIMENSIONS

Single Silo dimensions:
1,970mm high x 770mm diameter
A single Silo holds 800 litres.

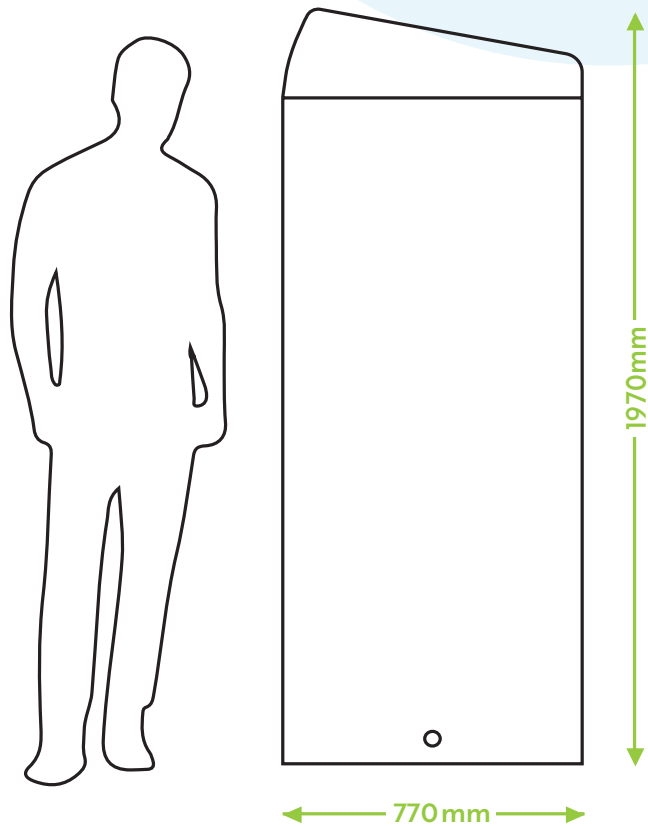

/ COLOUR OPTIONS

Birch Grey kept in stock, other colours available upon request.
Please Note: Printed colours will not be 100% accurate to tank colour.

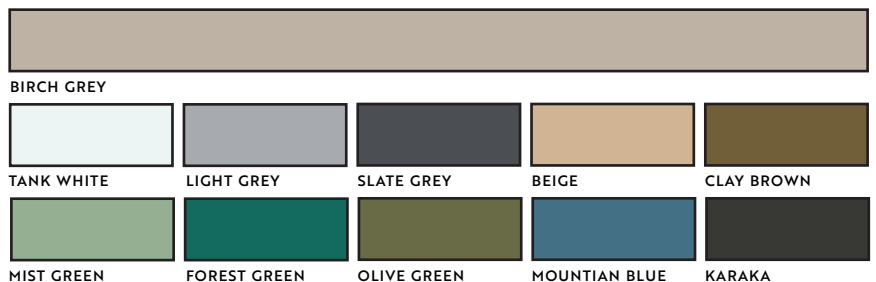

/ JOINED TANKS

Four Silo tanks - 3,200 litres.

Dimensions: 1970mm high x 3410mm long x 770mm deep

All Silo water tanks must be installed on a level concrete or compacted pebble slab. This slab must be at least 100mm longer and wider than the tanks.

E.g. Four joined Silo tanks require a concrete base at least 3610mm long x 970mm deep.

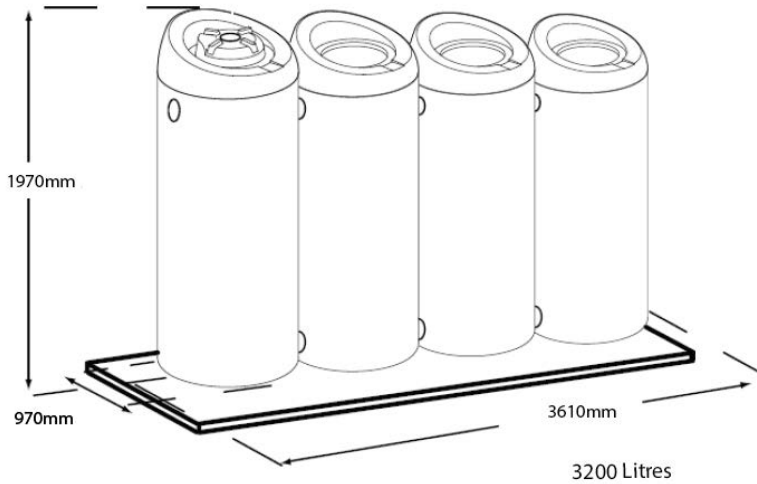

/ NEW ZEALAND MADE

Silo tanks are manufactured in New Zealand with tank grade plastic to withstand our harsh UV conditions. They are free of heavy metals, enabling an end-of-life recycling process! The tough polyethylene meets:

- AS/NZS 4020: 2002 Potable (Drinking) Water Standard
- AS/NZS 2070: Part 1 and Part 8 Australian Standards for Food Contact

This is great for a detention and re-use system as the water can be re-used for potable use.

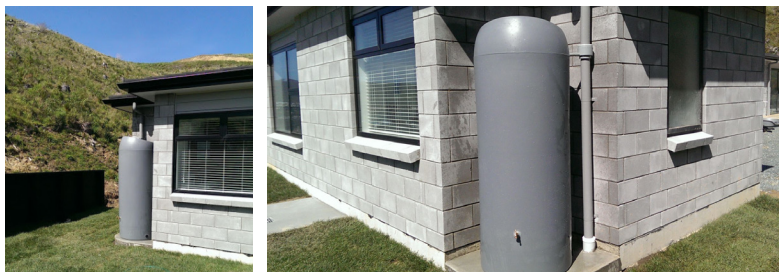

SPECIFY SILO!

Contact us for PSI and specifications for inclusion in your drawings. Easy to substitute from other unsightly or more costly above ground tanks. A range of pumps available depending on water use. Call us for details.

Silo

/ BENEFITS

Saves space – one of the slimmest above ground tanks on the market at only 770mm deep

Join individual Silo tanks together to hold even more water. Four Silo tanks = 3,200 litres

Quick and easy to install – simple connection to an existing downpipe

Easy to fit in tight corners or down the side of the house

Built in leaf strainer and lid unit

Tank grade plastic enables for potable water or stormwater - Ideal for re-use systems

Tank 1 x 15mm leaf strainer and lid unit

10 year warranty applies to all Silo tanks

One colour available: Birch Grey. Other colours available on request (Tank White, Light Grey, Slate Grey, Beige, Clay Brown, Mist Green, Forest Green, Olive Green, Mountain Blue and Black). Other colours available by special request.