

stormPANEL

DESIGNED FOR EASY EXPANSION

/ VERSATILE. RELIABLE. STRONG. COMPLIANT.



/ TANK DIMENSIONS

Single 1,000L stormPANEL dimensions:
1,950mm high x 1,520mm long x 460mm wide

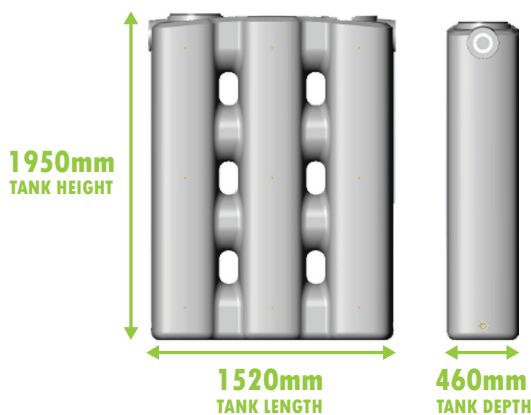

AVAILABLE NOW: Single 2,000L stormPANEL dimensions:
1,950mm high x 3,130mm long x 460mm wide.

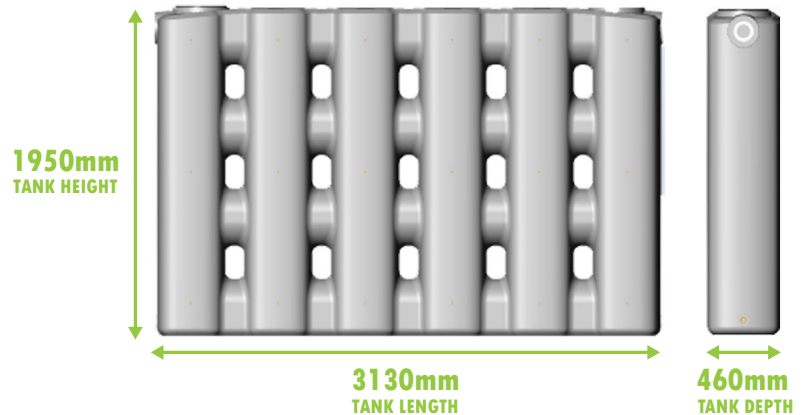

/ EASY SPECIFICATION

stormPANEL is designed to AS/NZS4766 by independent engineers with generic seismic and wind restraint systems for New Zealand's most trying areas - PSI documents for restraints are available with all stormPANEL tanks.

/ COLOUR OPTIONS

Please Note: Colours will not be 100% accurate to tank colour due to printing and digital variations.



/ DESIGNED TO BE SUSTAINABLE

stormPANEL tanks are manufactured from the highest quality polyethylene available which is ideally suited to our moulding technique giving long life and trouble-free service. The material is certified to AS/NZ4766:2006, AS/NZS4020:205, and AS/NZS 2070 so are suitable for potable water.

Polyethylene cannot rot or corrode and is UV stabilised for New Zealand's harsh environmental conditions. The manufacturing process produces zero waste of polyethylene and the product is 100% recyclable. At the end of its useful life, it can be returned to us to be recycled into other long-lasting products.

/ ULTRA SLIM DESIGN

When space is tight stormPANEL tanks are ideal for existing and new homes. The tanks are designed to not be seen and the ease of handling was part of the design process from the start.



TOP VIEW | 1,000L stormPANEL

/ stormPANEL COMPONENTS

PRODUCT	HEIGHT	WIDTH	DEPTH	WEIGHT
1,000L	1,950mm	1,530mm	460mm	60kg
2,000L	1,950mm	3,130mm	460mm	120kg
Restraint Pole Kit	2,250mm	75mm	50mm	30kg
Wall bracket restraint kit	-	-	-	2kg
50mm Multi-tank Connection Kit	-	-	-	-

Wall Restraint Kit

4x galvanized brackets, 4x M10 x 25mm bolts, 4x M10 washers



Pole Restraint Kit

4x galvanized 75x50mm RHS poles, 4x M10 x 75mm bolts, 4 x M10 washers, 2x Plastic end caps



50mm Multi-tank Base Connection Kit

50mm Hansen Union, 50mm Hansen nipple, 50mm x 150mm nipple, thread tape

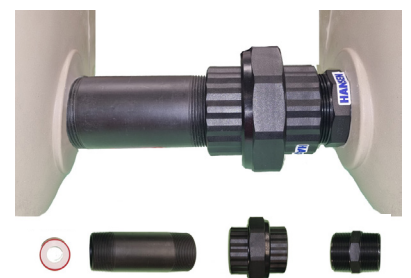

/ BENEFITS

Saves space – one of the slimmest above ground tanks on the market

Quick and easy to install – simple connection to an existing downpipe

Extra 25mm outlets for orifice overflow points or garden taps available to add on

2x 50mm brass BSP outlet - one at each end

Tank grade plastic enables for potable water or stormwater - Ideal for re-use systems

A 300mm lid is fitted for ease of inspection and cleaning

Designed with moulded in lifting lugs for certified shackles

The 1,000L and 2,000L models have been designed to connect together to increase volume